

DC Square-body Fuses Sizes 300 - 302 - 2x302 SR Brackets size 300 - 2400V DC

SRE from 20 to 180 A

Dimensions

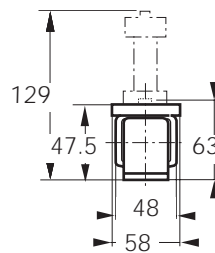
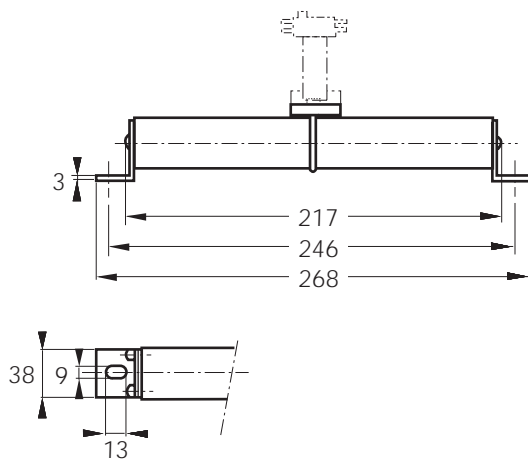

Weight: 1150 g

Main Characteristics

Size	Current rating I_N (A)	Breaking Capacity	Watts loss		Max. I^2t @ 2000 V		Designation	Ref. Number	Catalog Number
			$0.8 I_N$ (W)	I_N (W)	L/R = 15 ms (A ² S)	L/R = 45 ms (A ² S)			
300	20	@ 2400 V DC 100 kA L/R = 15 ms	18	36	150	260	CC 24 SRE 300 QF 0020	X075299	D300SE24C20QF
	25		21	42	260	460	CC 24 SRE 300 QF 0025	W075298	D300SE24C25QF
	32		22	43	310	540	CC 24 SRE 300 QF 0032	G079471	D300SE24C32QF
	40		26	51	530	920	CC 24 SRE 300 QF 0040	H079472	D300SE24C40QF
	50		32	62	750	1300	CC 24 SRE 300 QF 0050	J079473	D300SE24C50QF
	63		35	69	1650	2900	CC 24 SRE 300 QF 0063	K079474	D300SE24C63QF
	80		38	75	3700	6500	CC 24 SRE 300 QF 0080	L079475	D300SE24C80QF
	100		41	80	8000	14000	CC 24 SRE 300 QF 0100	M079476	D300SE24C100QF
	125		49	95	14000	25000	CC 24 SRE 300 QF 0125	N079477	D300SE24C125QF
	160		50	96	34000	60000	CC 24 SRE 300 QF 0160	P079478	D300SE24C160QF
180	51	98	57000	100000	CC 24 SRE 300 QF 0180	Q079479	D300SE24C180QF		

Pack: 1 piece

Microswitch MC 2R 3E 1-5N BS Ref. Number: J310025



DC Square-body Fuses Sizes 300 - 302 - 2x302 SR Brackets size 300 - 2400V DC



SRE from 20 to 180 A

Electrical characteristics DC applications data

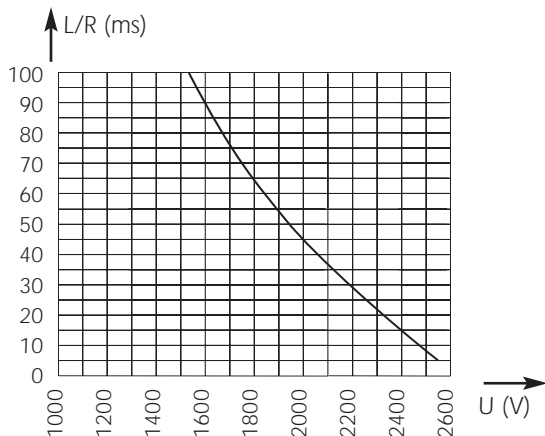

Above: Curve indicates maximum permissible value of time constant L/R as a function of DC working voltage

Max. AC voltage (50/60 Hz):
 2000 V with breaking capacity of 80 kA

Time vs. current characteristics

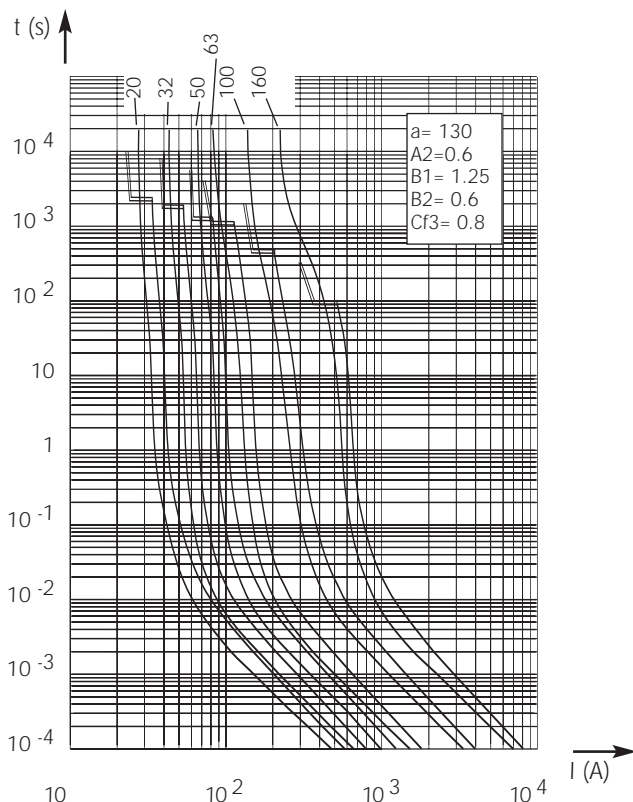

Peak arc voltage vs. working voltage

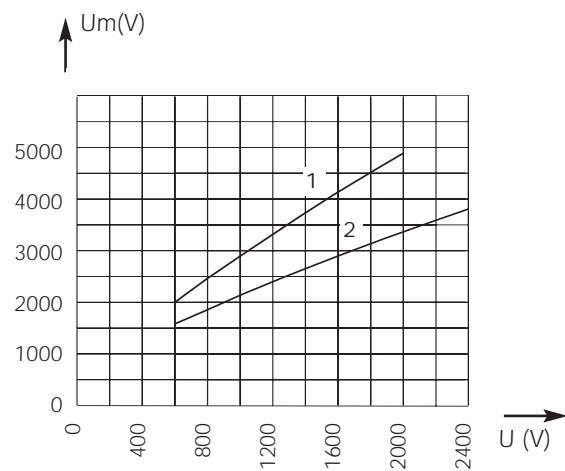

1 : L/R = 45 ms
 2 : L/R = 15 ms

Above: Curves indicate for various time constants L/R the peak arc voltage which may appear across fuse terminals, vs. DC working voltage

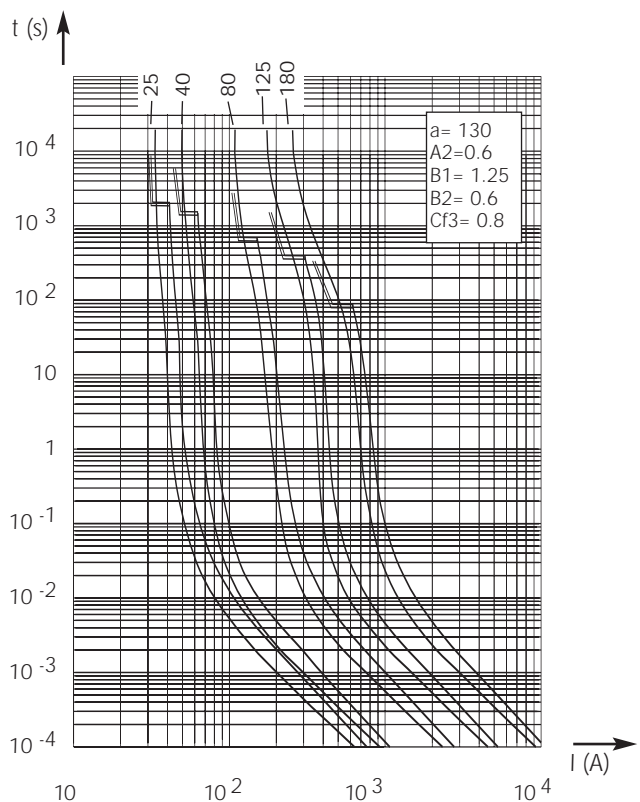

Above: Curves indicate, for each rated current, pre-arc

